

H 9150

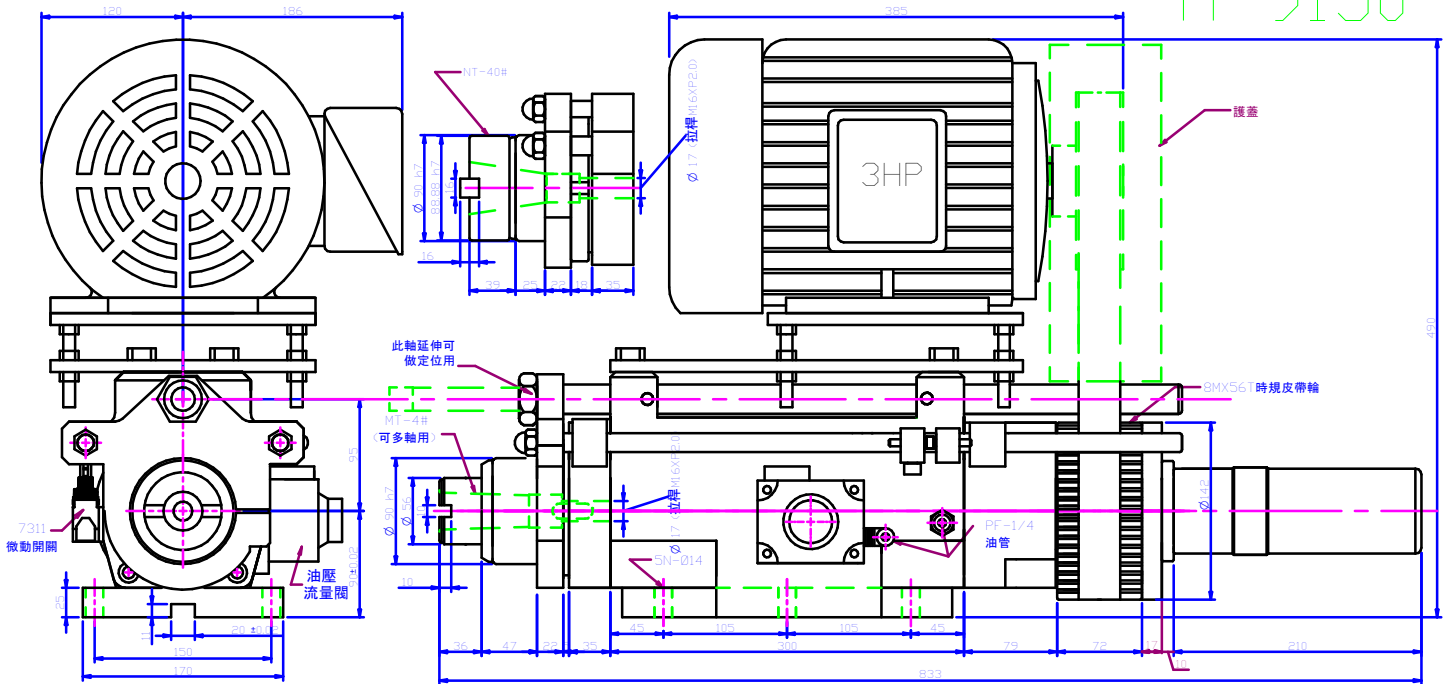

Operating Pressure	20~25kg/cm ²	Max. Speed	1,500 R.P.M	Cylinder Diameter	Ø110
Max. Drilling Capacity	Ø35(S45C)	Weight	82KG	Cylinder Area	Forward : 70.25CM ²
Spindle Taper	*NT-40/*MT-4/*ER40	Spindle Stroke	150MM		Reverse : 31.4CM ²
Motor	2.2KW-2P,4P,6P	Breaking Stroke	Adjust By Flow Control Valve	Thrust	1405KG(20KG/CM) ²
				Spindle Speed	Optiona : 500RPM~1500RPM
Wearing Parts					
Spindle Bearing	32010X1,32009X1,6010VX1	Piston Seal	P-100X3,G-70X1		
Pully Bearing	51213X1,6013ZZX1	Oil Seal -Back Cover	G-105X1,USH-55X1,DH-55X1,P55X1		
Oil Seal - Front Cover	DH-90X1,P-90X2,G-105X2	Belt	8M Timing Belt		
Limit Switch	7311X2				